

DIRECTION OF ROTATION

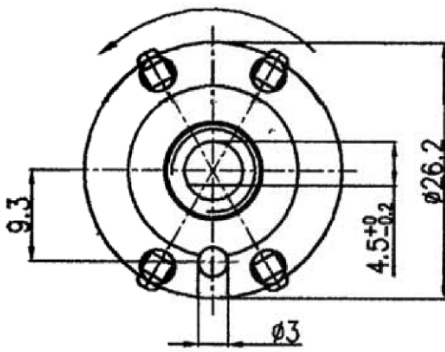

NUT 1PC

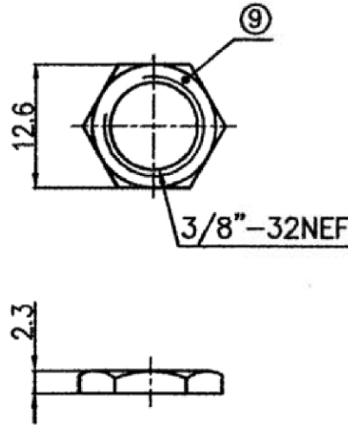

WASHER 1PC t=0.5

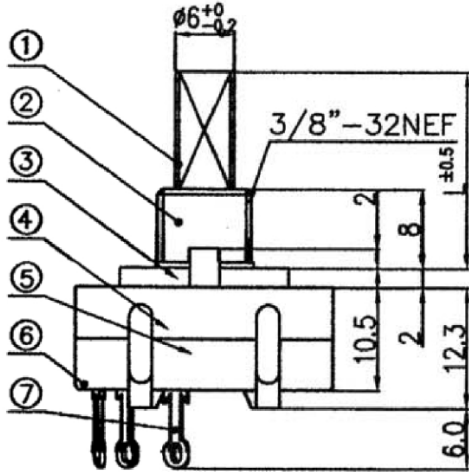
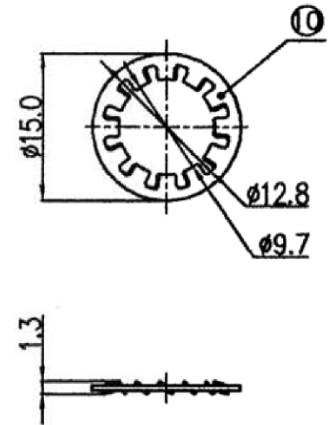

CENTER PLATE 1 PCS

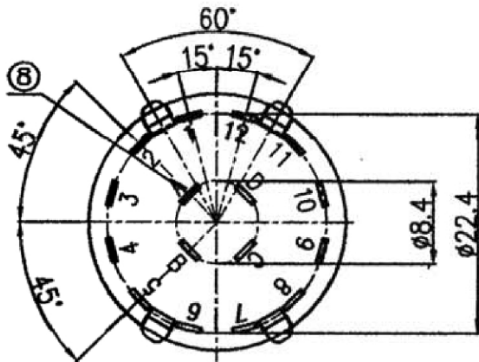
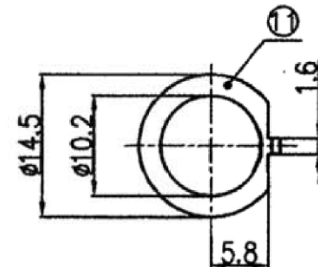

SCHEMATIC

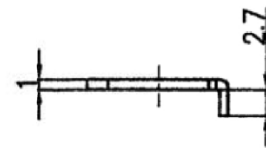
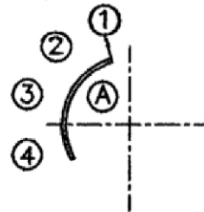

11	SR2630	Lock Washer	1	SPCE-tt=1.0	MFN-I	NO	MODEL	F	L	NO	MODEL	F	L
10	W-3/8"	Washer	1	Stell t=0.5	Zinc Plating	✓	15F	7	15		13F	5	13
9	N-3/8"	NUT	1	Stell t=2.3	Zinc Plating		18F	10	18		21F	13	21
8	SR26105-6	Internal terminal	1	Brass	Silver Plating		28F	20	28		23F	15	23
7	SR26105N	External terminal	4	Brass	Silver Plating		38F	30	38		33F	25	33
6	SR2611-4C	Element	1	Nylon+30%FB	No Plating								
5	SR2527	Stell Ball	2	Stell	Silver Plating								
4	SR2615	Spring	1	SWPA	Silver Plating	△							
3	SR2606	Contact Plate	1	Phosphor-bronze	Silver Plating	△							
2	SR2609	Case	1	Nylon+30%FB	No Plating	△							
1	SR2601-F	Shaft	1	POM	No Plating	△							

NO	Part No	Description	Q'TY	Material	Finishing	MODEL NAME	SR261-1-4-15F-N			A
----	---------	-------------	------	----------	-----------	------------	-----------------	--	--	---

TOLERANCES		DIMENSION	SCALE	DRAWING BY	CHECKED BY	APPROVED BY	DRAWING NO.
less than 10	± 0.3	m/m	/				SR261-092
above 10 - 30	± 0.5						
above 30 - 100	± 1.0						
angular dimension	± 5 °						Switch\SR261\Spec

